

# Owner's Manual

- *Installation*
- *Use*
- *Maintenance*



**INDEX**

<b>1.</b>	<b>INTRODUCTION</b> .....	Page 4
<b>2.</b>	<b>DESCRIPTION OF SYMBOLS</b> .....	Page 4
<b>3.</b>	<b>SAFETY</b> .....	Page 5
	3.1 General safety instructions .....	Page 5
	3.2 High pressure unit safety requirements .....	Page 5
	3.3 Safety during operation .....	Page 5
	3.4 General procedures for using nozzles .....	Page 5
	3.5 Safety during unit maintenance .....	Page 6
<b>4.</b>	<b>PUMP IDENTIFICATION</b> .....	Page 6
<b>5.</b>	<b>TECHNICAL CHARACTERISTICS</b> .....	Page 7
<b>6.</b>	<b>DIMENSIONS AND WEIGHT</b> .....	Page 8
<b>7.</b>	<b>OPERATING INSTRUCTIONS</b> .....	Page 9
	7.1 Water temperature .....	Page 9
	7.2 Maximum flow and pressure rates .....	Page 9
	7.3 Minimum RPM .....	Page 9
	7.4 Recommended lubricant types and Manufacturers .....	Page 9-10
<b>8.</b>	<b>PORTS AND CONNECTIONS</b> .....	Page 11
<b>9.</b>	<b>PUMP INSTALLATION</b> .....	Page 12
	9.1 Installation .....	Page 12
	9.2 Direction of rotation .....	Page 13
	9.3 Version change and reducer positioning .....	Page 13
	9.4 Hydraulic connections .....	Page 14
	9.5 Pump power supply .....	Page 14
	9.6 Suction line .....	Page 15
	9.7 Filtration .....	Page 15
	9.8 Outlet line .....	Page 16
	9.9 Internal diameter of hose .....	Page 17
	9.10 V-belt transmission .....	Page 18
<b>10.</b>	<b>START UP AND OPERATION</b> .....	Page 18
	10.1 Preliminary inspections .....	Page 18
	10.2 Starting up .....	Page 19
<b>11.</b>	<b>PREVENTATIVE MAINTENANCE</b> .....	Page 19
<b>12.</b>	<b>PUMP STORAGE</b> .....	Page 20
	12.1 Filling the pump with anti-corrosion emulsion or anti-freeze .....	Page 20
	12.2 Hoses .....	Page 20
<b>13.</b>	<b>PRECAUTIONS AGAINST FREEZING</b> .....	Page 20
<b>14.</b>	<b>WARRANTY TERMS</b> .....	Page 20
<b>15.</b>	<b>TROUBLESHOOTING</b> .....	Page 21
<b>16.</b>	<b>EXPLODED VIEWS AND PARTS</b> .....	Page 22-25

## INDEX

<b>17. SPECIAL VERSIONS</b> .....	Page 26
<b>17.1 MWN Pump</b> .....	Page 26
17.1.1 Operating instructions .....	Page 26
17.1.2 Water temperature .....	Page 26
17.1.3 Maximum pressure and flow rate .....	Page 26
17.1.4 Minimum RPM .....	Page 26
17.1.5 Technical characteristics .....	Page 26
17.1.6 Dimensions and weight .....	Page 27
17.1.7 Exploded view .....	Page 31
<b>17.2 MWR Pump</b> .....	Page 32
17.2.1 Operating instructions .....	Page 32
17.2.2 Water temperature .....	Page 32
17.2.3 Maximum pressure and flow rate .....	Page 32
17.2.4 Minimum RPM .....	Page 32
17.2.5 Technical characteristics .....	Page 32
17.2.6 Dimensions and weight .....	Page 33
17.2.7 Exploded view .....	Page 37
<b>17.3 MWNR Pump</b> .....	Page 38
17.3.1 Operating instructions .....	Page 38
17.3.2 Water temperature .....	Page 38
17.3.3 Maximum pressure and flow rate .....	Page 38
17.3.4 Minimum RPM .....	Page 38
17.3.5 Technical characteristics .....	Page 38
17.3.6 Dimensions and weight .....	Page 39
17.3.7 Exploded view .....	Page 43
<b>17.4 MWF Pump</b> .....	Page 44
17.4.1 Operating instructions .....	Page 44
17.4.2 Water temperature .....	Page 44
17.4.3 Maximum pressure and flow rate .....	Page 44
17.4.4 Minimum RPM .....	Page 44
17.4.5 Technical characteristics .....	Page 44
17.4.6 Dimensions and weight .....	Page 44
17.4.7 Minimum Rotating Speed .....	Page 44
17.4.8 Flushing circuit diagram of use .....	Page 45
<b>18. REPAIR TOOLS</b> .....	Page 46
<b>19. MAINTENANCE LOG</b> .....	Page 47

## 1. INTRODUCTION

This manual describes the use and maintenance instructions of the MW pump, and should be carefully read and understood before using the pump.

Correct use and adequate maintenance will guarantee the pumps trouble-free operation for a long time. General Pump declines any responsibility for damage caused by misuse or the non-observance of the instructions indicated in this manual.

Upon receiving the pump, check that it is complete and in perfect condition. Should anything be found out of order, please contact us before installing and starting the pump.

## 2. SYMBOL DESCRIPTIONS



**Warning**  
Potential Danger

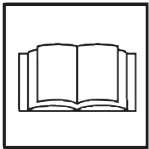

Read carefully and understand  
the manual before operating  
the pump



**Danger**  
High Voltage



**Danger**  
Wear protective mask



**Danger**  
Wear goggles



**Danger**  
Wear protective gloves



**Danger**  
Wear protective boots

### 3. SAFETY

#### 3.1 General Safety Indications

Improper use of pumps and high pressure systems, and the non-compliance with installation and maintenance instructions may cause severe injury to people and/or damage to property. Anyone assembling or using high pressure systems must possess the necessary competence to do so, should be aware of the characteristics of the components assembled/used, and must take all precautions necessary to ensure maximum safety in any operating condition. In the interest of safety, both for the Installer and the Operator, no reasonably applicable should be omitted.

#### 3.2 High pressure unit safety requirements

1. The pressure line must always be equipped with a safety valve.
2. High pressure system components, in particular for those units working outside, must be adequately protected against rain, frost and heat.
3. The electrical control system must be adequately protected from water spray, and must comply with the specific regulations in force.
4. High pressure hoses must be properly sized for maximum operating pressure of the system and always and only used within the operating pressure range specified by the hose manufacturer. The same rules should be observed for all other auxiliary systems affected by high pressure.
5. The ends of high pressure hoses must be sheathed and secured to a solid structure to prevent dangerous whiplash in case of bursting or broken connections.
6. Appropriate safety guards must be provided for the pump transmission systems (couplings, pulleys and belts, auxiliary drives).



#### 3.3 Safety During Operation

The working area of a high pressure system must be clearly marked. Access must be prohibited to un-authorized personnel and, wherever possible, the area should be restricted or fenced. The personnel authorized to access this area should first be trained, and informed about the risks that may arise from failures or malfunctions of the high pressure unit.

Before starting the unit, the operator must check:

1. That the high pressure system is properly powered (see paragraph 9.5).
2. That pump intake filters are perfectly clean; we advise the use of a device that indicates the filters clogging level.
3. Electrical parts are adequately protected and in perfect condition.
4. The high pressure hoses do not show apparent signs of abrasion, and that fittings are in perfect shape.

Any fault or reasonable doubt that may arise before or during operation should be promptly reported and verified by competent personnel. In these cases, pressure should immediately be released and the high pressure system stopped.



#### 3.4 General Procedures For Using Nozzles

1. The Operator must always place his own and other worker's safety before any other interest; his and should always be governed by good sense and responsibility.
2. The Operator must always wear a helmet with a protective visor, waterproof clothing, and appropriate boots capable of guaranteeing grip on wet pavement.

*Note: appropriate clothing will effectively protect against water spray, but it may not offer adequate protection against the direct impact of water jets or sprays from a close distance. Some circumstances may require further protection.*

3. It is generally best to organize personnel into teams of at least two people capable of giving mutual and immediate assistance in case of necessity and of taking turns during long and demanding operation.
4. Access to the work area that is within the water jets' range must be absolutely prohibited to and free from objects that, inadvertently under a pressure jet, can be damaged and or create dangerous situations.
5. The water jet must only and always be directed in the direction of the work area, including during testing or preliminary tests or checks..
6. The Operator must always pay attention to the trajectory of the debris removed by the water jet. If necessary, suitable guards must be provided by the Operator to protect anything that may be accidentally exposed.
7. The Operator should not be distracted for any reason during operation. Workers needing to access the operating area must wait for the Operator to stop work, and then immediately make their presence known.
8. For safety reasons, it is important that each member of the team is fully aware of the intentions and actions of other team members in order to avoid dangerous misunderstandings.
9. The high pressure system must not be started up and run under pressure without all team members in position and without the Operator having already directed his/her lance toward the work area.

### 3.5 Safety During System Maintenance

1. The pressure system maintenance must be carried out in the time intervals set by the manufacturer who is responsible for the whole group according to law.
2. Maintenance should always be carried out by trained and authorized personnel.
3. Assembly and disassembly of the pump and its various components must be performed exclusively by authorized personnel, using appropriate equipment in order to avoid damage to components and connections.
4. Always use original spare parts to ensure total reliability and safety.

## 4. PUMP IDENTIFICATION

Each pump has a specific label which contains:

Pump model and version  
Serial Number  
Flow Rate - GPM  
Pressure - PSI  
Power - Hp-kW  
Maximum RPM



**Pump model, version and serial number must always be specified when ordering spare parts.**

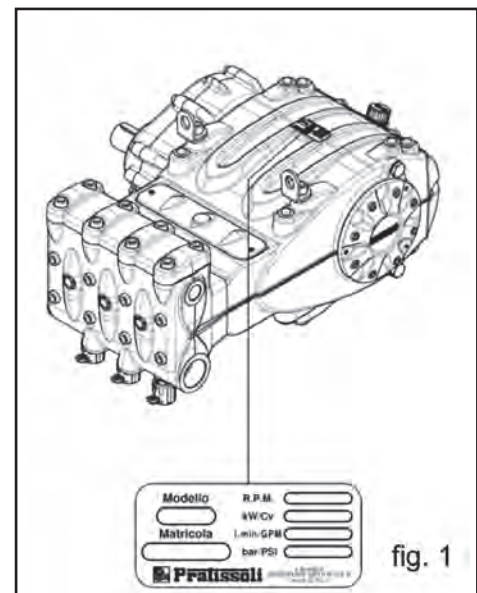

**5. TECHNICAL FEATURES**

MODEL	RPM	FLOW RATE		PRESSURE		POWER	
		GPM	l/min	PSI	Bar	Hp	kW
<b>MW32A</b>	1500/1800/2200	36.0	136	4350	300	106	79
<b>MWS36A</b>	1500/1800/2200	45.5	172	3900	269	121	90
<b>MWS40A</b>	1500/1800/2200	56.0	213	3050	210	117	87
<b>MWS45A</b>	1500/1800/2200	71.0	269	2500	172	121	90
<b>MWS50A</b>	1500/1800/2200	87.5	333	2000	138	119	88
<b>MWS55A</b>	1500/1800/2200	105.5	400	1450	100	104	77.5



**6. DIMENSIONS AND WEIGHT**

For dimensions and weight of MW32A, MWS36A and MWS40A pumps, please refer to fig. 2.

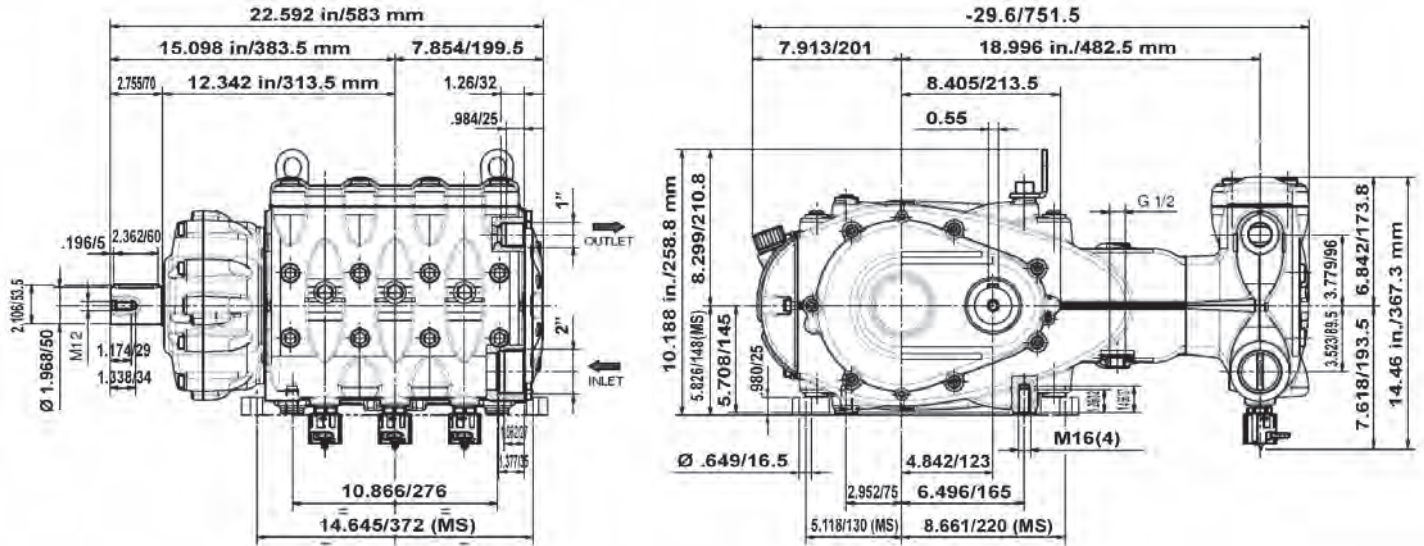

**Weight: 540 Lbs./244 Kg.**

fig. 2

For dimensions and weight of MWS45A, MWS50A and MWS55A pumps, please refer to fig. 2a.

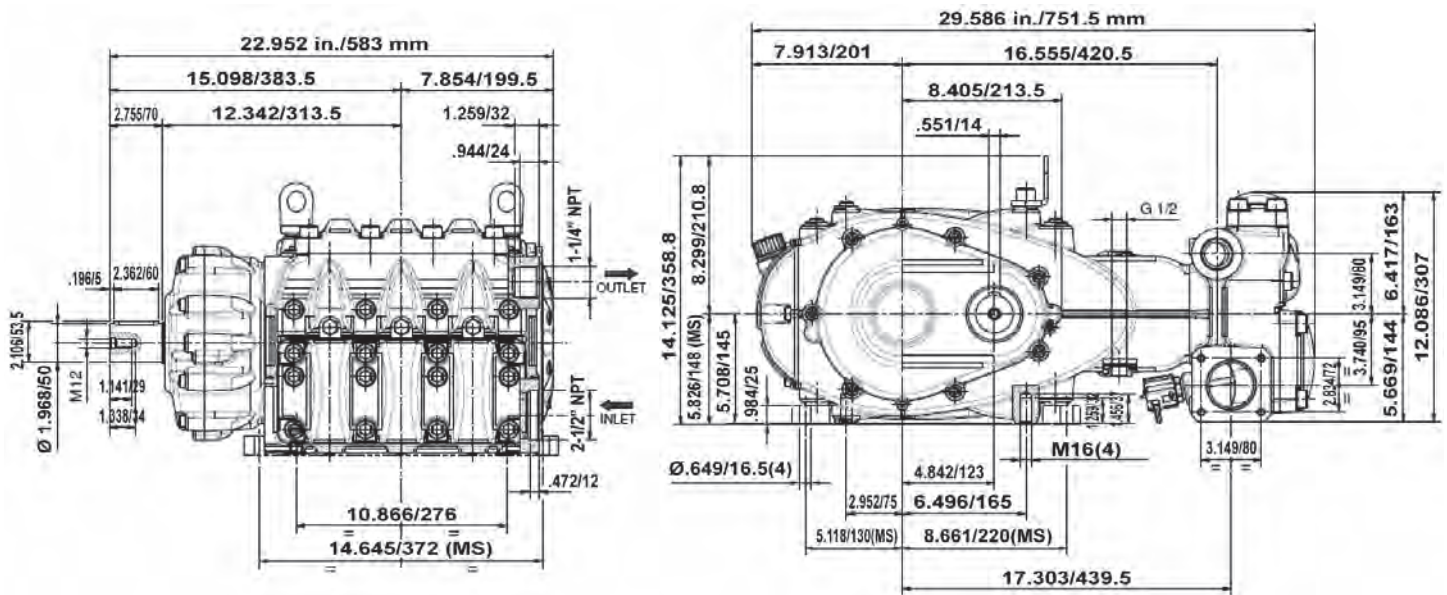

**Weight: 540 Lbs./245 Kg.**

fig. 2a



## 7. INFORMATION ABOUT PUMP USE



The MW/S pump was designed to operate with filtered water (see paragraph 9.7) and at maximum temperature of 104<sup>0</sup> F (40<sup>0</sup> C).

**Other fluids may be used only upon the approval of The Customer Service Department .**

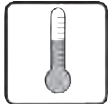

### 7.1 Water Temperature

The max water temperature is 104<sup>0</sup> F (40<sup>0</sup> C). However, it is possible to use the pump at temperatures of up to 140<sup>0</sup>F (60<sup>0</sup>C) for short periods of time. In this case we advise consulting the Customer Service Department.

### 7.2 Max Flow Rate and Pressure Values

The performance values indicated in the catalog refer to the maximum performance of the pump. Regardless of the power used, pressure and maximum RPM values indicated on the plate may not be exceeded unless expressly authorized by the **Customer Service Department**.

### 7.3 Lowest RPM

Any RPM value different from what is indicated in the performance table (see chapter 5) must be expressly authorized by the **Customer Service Department**.

### 7.4 Recommended Lubricant Oil Types & Manufacturers

The pump is delivered with lubricant oil compliant with room temperatures ranging between 32<sup>0</sup> and 89.6<sup>0</sup> F (0<sup>0</sup> and 30<sup>0</sup>C ). Some recommended lubricant types are indicated in the table below; these lubricants are treated with additives in order to increase corrosion protection and resistance to fatigue. As an alternative, Automotive SAE 85W-90 gearing lubricants may also be used.

BRAND	TYPE
<b>GENERAL PUMP</b>	<b>SERIES 220</b>
ARAL	Aral Degol BG220
BP	ENERGOL HLP 220
CASTROL	Hyspin VG 220, Magna 220
ELF	POLYTELIS 220
ESSO	NUTO 220
FINA	Cirkan 220
FUCHS	RENOLIN 220
MOBIL	DTE OIL BB
SHELL	TELLUS C 220
TEXACO	RANDO HD 220
TOTAL	CORTIS 220

Check the oil level by using the oil level dipstick (1), fig. 3. Refill if necessary to top off level. Correct oil level inspection is done with the pump at room temperature; oil is changed with the pump at working temperature, by removing the rear plug (2), fig 3..

Checking and changing oil is to be carried out as indicated in Chapter 11. The amount required is 304 oz. (9 liters).

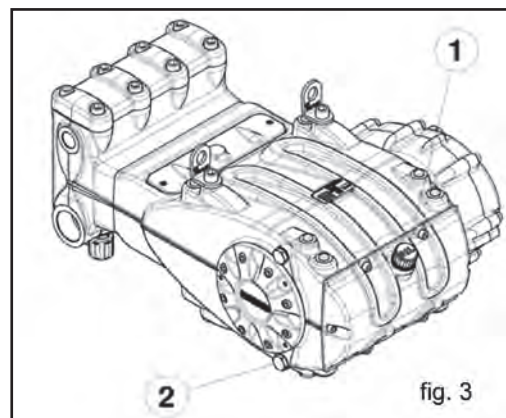



In any case, oil must be changed at least once a year since it may deteriorate by oxidation.

For room temperatures that differ from that mentioned earlier, follow the indications contained in the diagram below, keeping in mind that the oil must have a minimum viscosity of 180 cSt.

**VISCOSITY/ROOM TEMPERATURE DIAGRAM**

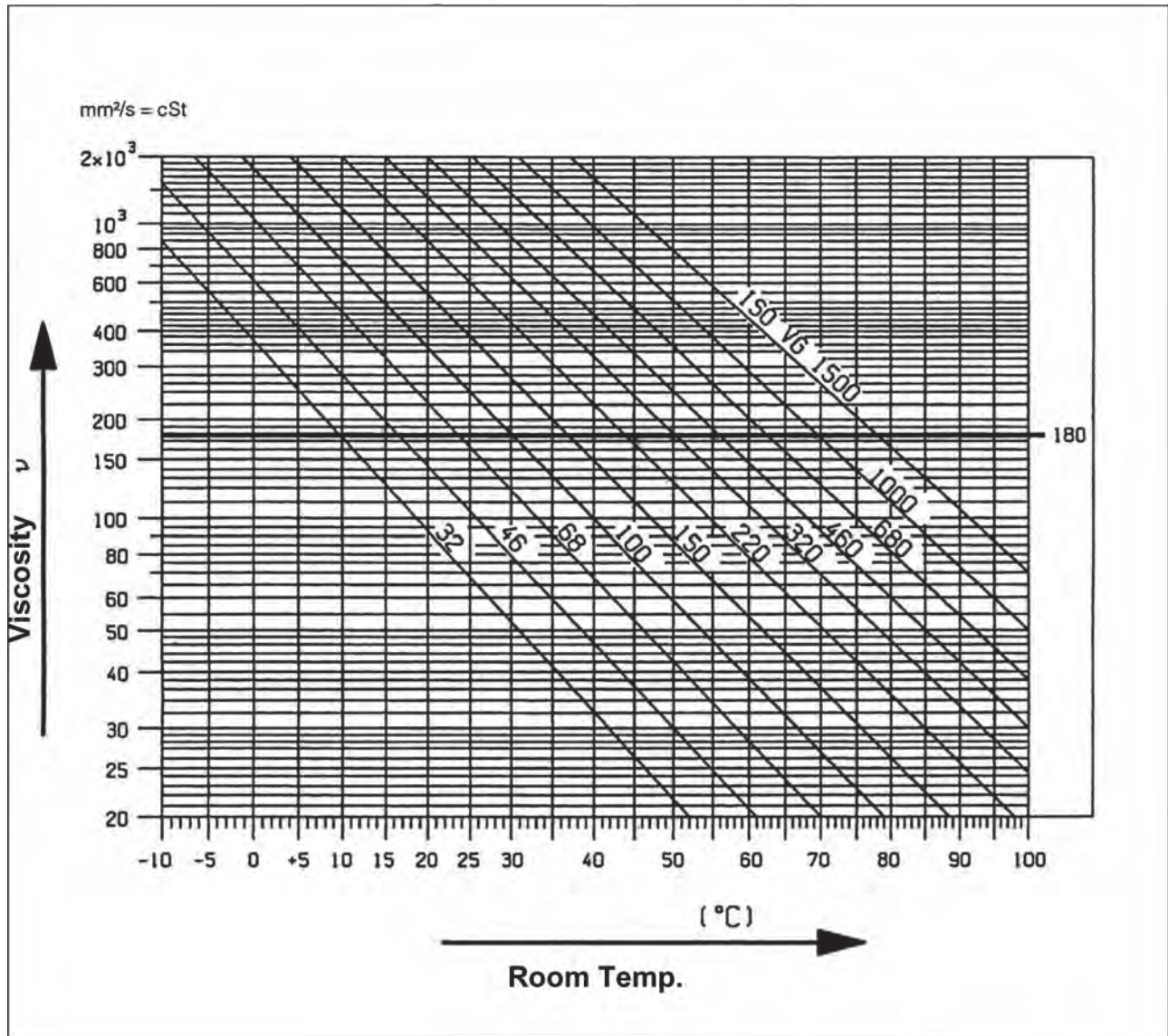

Exhausted oil must be collected in an appropriate recipient and disposed of in appropriate locations. In absolutely no case may it be dispersed into the environment.

## 8. PORTS AND CONNECTIONS

MW/S Series pumps are equipped with (see fig. 4 and 4a):

1. 2 inlet ports "IN", 2" NPT (MW32A, MWS36A, MWS40A).  
2 inlet ports "IN", 2-1/2" NPT (MWS45A, MWS50A, MWS55A).

The line can be connected to either of the two inlet ports; the ones not being used must be hermetically sealed.

2. 2 outlet ports "OUT", Ø 1" NPT-F (MW32A, MWS36A, MWS40A).  
2 outlet ports "OUT", Ø 1-1/4" NPT-F (MWS45A, MWS50A, MWS55A).
3. 1 drain port "DRAIN" with G1/2" hole in the lower cover to monitor any water leakage due to wear of the pressure packings. In case of leaks, please consult the repair manual.  
**This hole must always be kept open.**

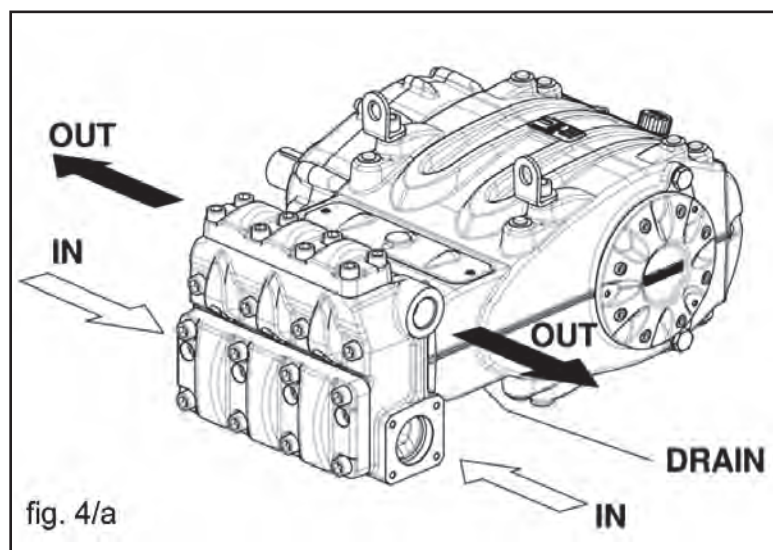
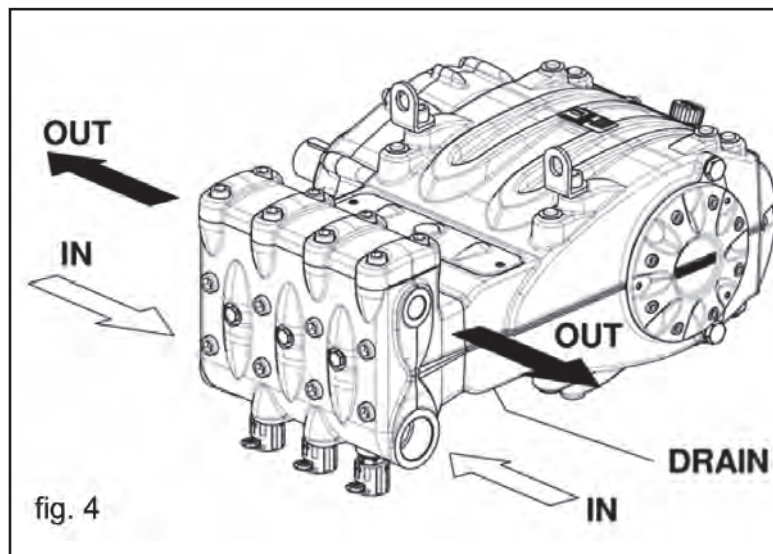

## 9. PUMP INSTALLATION

### 9.1 Installation

The pump must be installed in a horizontal position using the M16 threaded support feet. Tighten the screws with a torque of 200 Nm (147.5 Ft-Lb)

The base must be perfectly flat and rigid enough as not to allow bending or misalignment on the pump coupling and axis/transmission due to torque transmitted during operation.

Two lifting brackets are mounted on the pump for easy installation, as per the figure below.



**The brackets are sized solely for pump lifting and therefore are absolutely not permitted for use of additional loads.**



**Replace the oil filling hole closing service plug positioned on the rear casing cover with the plug with oil dipstick. Check the correct quantity.**

The dipstick must always be reachable, even when the unit is assembled.



**The pump's shaft (PTO) must not be rigidly connected to the motor unit.**

The following transmission types are suggested:

- Flexible joint
- Cardan Joint (please respect the maximum working angles indicated by the manufacturer)
- Belts; for correct application, please contact the Customer Service Department.



### 9.2 Direction of rotation

The PTO rotation is indicated by an arrow located on the reduction gear cover. From a position facing the pump head, the rotation direction will be as in fig. 5.

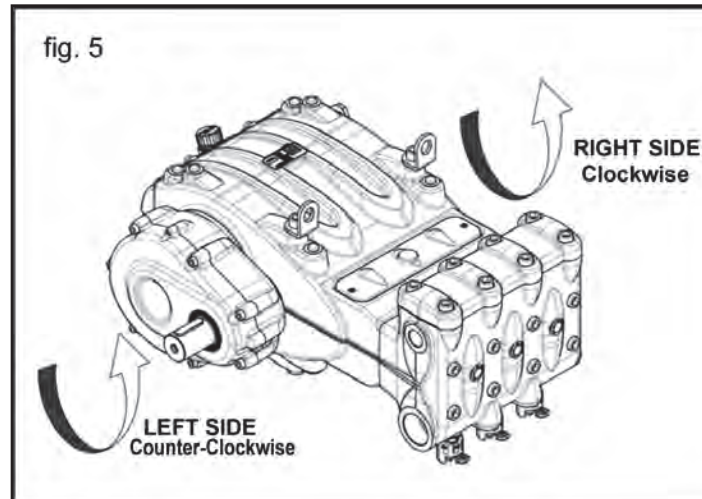

### 9.3 Version Change and Reducer Positioning

A right version pump is defined when: observing the pump from the head side, the PTO shank of the pump shaft is on the right side.

A left version pump is defined when: observing the pump from the head side, the PTO shank is on the left side. See fig. 5.



**The version may be changed only by trained and authorized personnel by carefully following the instructions in the repair manual.**

1. Separate the pump head from the power end (crankcase) as indicated in Chapter 2 in points 2.2.1 and 2.2.3 of the Repair Manual.
2. Turn the power end (crankcase) 180° and reposition the rear casing cover in such a way that the oil dipstick is turned upward. Reposition the lifting bracket and relative hole closing plugs in the upper part of the casing. Invert the two inspection covers, ensuring that the open one is positioned lower. Finally, properly reposition the specification label in its housing on the casing.



**Make sure that the lower inspection cover draining holes are open.**

3. Reassemble the pump head with the power end (crankcase) as indicated in Chapter 2 in points 2.2.1 and 2.2.4 of the Repair Manual.

It is also possible to place the reduction gear in 5 different positions as per fig. 6.

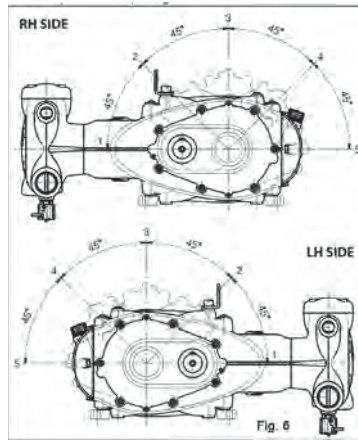

fig. 6



The reducer's position may be changed only by trained and authorized personnel by carefully following the instructions in the repair manual.

**9.4 Hydraulic Connections**

In order to isolate the system from the vibrations produced by the pump, we advise to build the first section of the duct near the pump (both for intake and delivery) with flexible hose. The consistency of the intake section must allow to avoid deformation caused by the depressurization produced by the pump.

**9.5 Pump Power Supply**

MW/S pumps must always be installed under positive head, i.e. they must receive water by gravity or by forced feeding, and never suctioned from a lower level. The pumps can tolerate minimum NPSH even as low as 1 m. (3.28 ft.), however, to obtain a better volumetric efficiency and above all to avoid cavitation, the minimum NPSH available, measured at the pump inlet flange, will have to be at least equal or higher than the values shown in the chart below.

	MW32A	MWS36A	MWS450A	MWS45A	MWS50A	MWS55A
<b>NPSH<sub>r</sub> (ft)</b>	4.5	5.5	6.5	7.5	8	9

For higher cylinder capacity pumps (MWS45A-S50A-S55A), it is strongly recommended to use a booster pump to avoid cavitation, in view of the geometry on the hydraulic section and of the remarkably high flow rates.

The booster pump must have the following specifications: flow rate at least double the rated flow rate of the pump, and pressure between 30 to 40 PSI (2 to 3 Bar). These feeding conditions must be respected at any operating RPM.



Booster start-up must always precede plunger pump start-up. In order to protect the pump, we advise to install a pressure switch on the feeding line after the filters.



**9.6 Suction Line**

For the pump's correct operation, the suction line must have the following characteristics:

1. Minimum internal diameter as indicated in the diagram in paragraph 9.9, and in any case equal or greater than the pump head's value. Along the duct, avoid localized diameter reductions that may cause pressure drops with subsequent cavitation. Absolutely avoid 90° elbows, connections with other hoses, bottlenecks, counter-slopes, upside down "U" shaped curves, "T" connections.
2. With a layout that is set in such a way to prevent cavitation.
3. It should be perfectly airtight, and built in a way that guarantees perfect sealing over time.
4. Avoid pump emptying when stopping (even partial emptying).
5. Do not use hydraulic fittings, 3 or 4 way fittings, adapters, etc., since they may hinder the pump's performance.
6. Do not install Venturi tubes or injectors for detergent intake.
7. Avoid the use of standing valves, check valves, or any other type of one-way valves.
8. Do not connect the by-pass line from the valve directly to the pump suction line.
9. Provide appropriate baffle plates inside the tank in order to avoid water flows coming from both the by-pass and feeding which lines may create turbulence near the tank's outlet port.
10. Make sure that the suction line is perfectly clean inside before connecting it to the pump.
11. The pressure gauge for checking booster pressure must be installed near the plunger pump's inlet port, and always downstream from the filters.

**9.7 Filtering**

On the suction line, install two filters as indicated in fig. 7 and fig. 7/a.

**With the manual adjustment valve:**

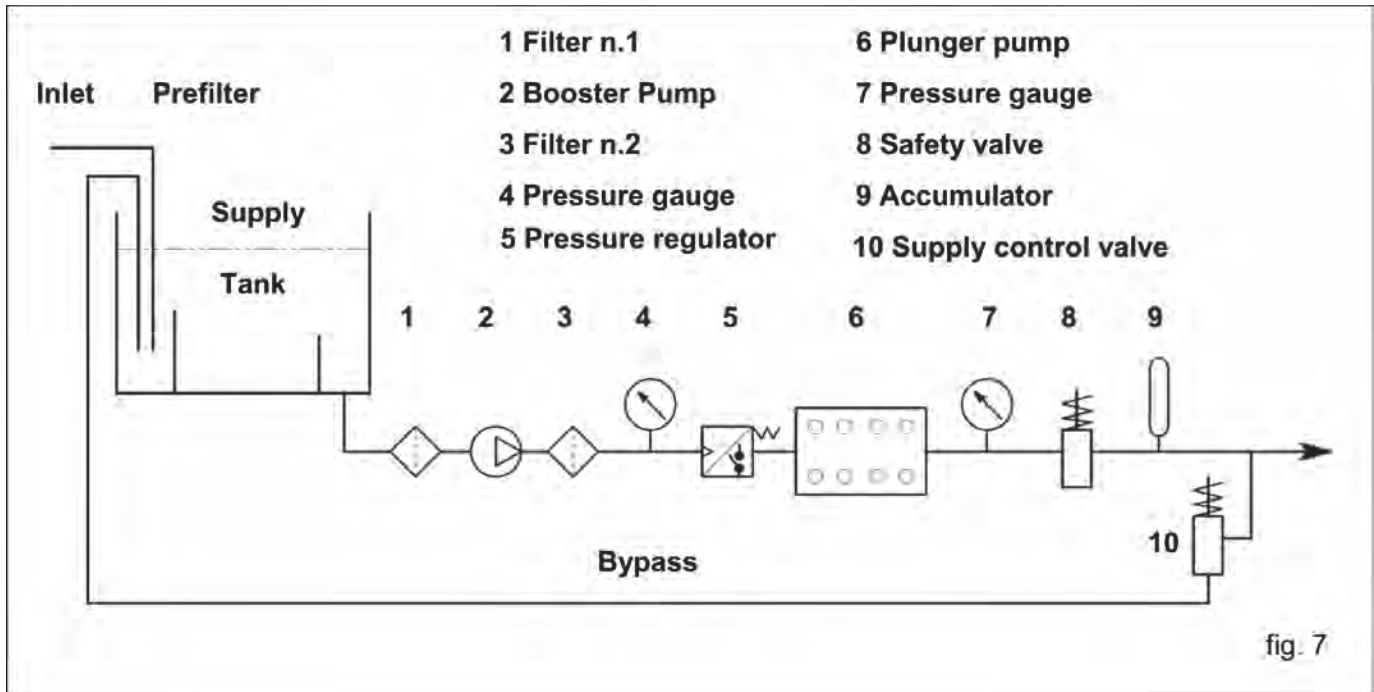

With the pneumatic adjustment valve:

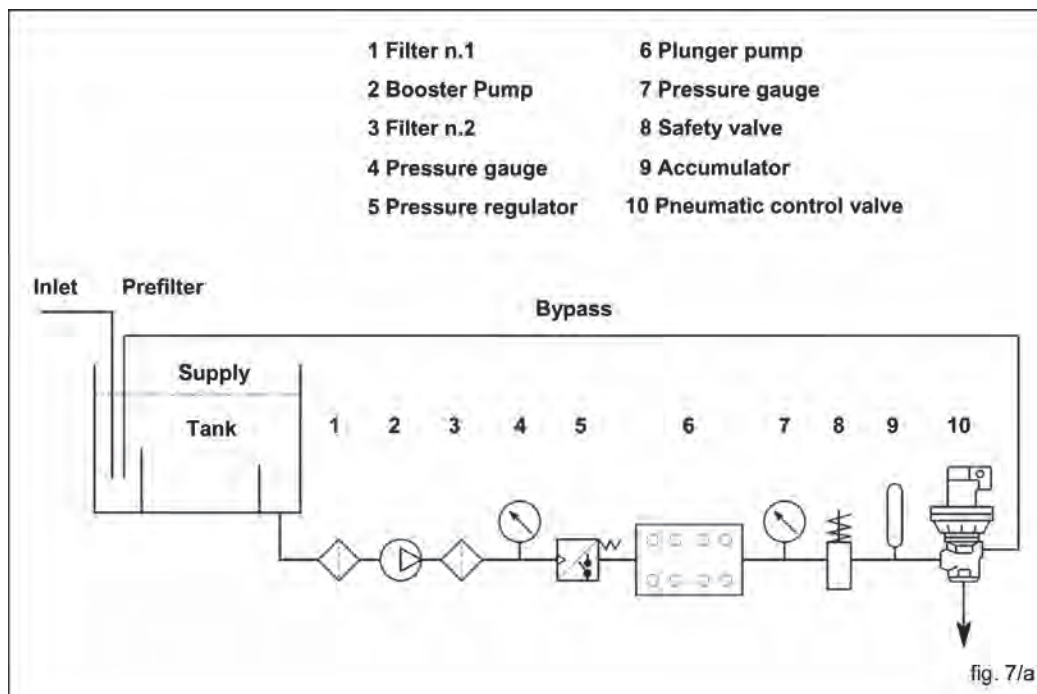

The filter must be installed as close as possible to the pump, should allow easy inspection and have the following characteristics:

1. Minimum capacity 3 times greater than the pump's rated flow value.
2. Filter port diameters must not be smaller than the pump inlet ports.
3. Filtration degree ranging between 200 and 360  $\mu\text{m}$ .



**In order to guarantee correct pump operation, it is important to plan periodical cleaning of the filter depending on actual pump usage, water quality and actual clogging conditions.**

### 9.8 Outlet Line

To obtain a correct delivery line, please comply with the following installation instructions:

1. The internal diameter of the hose must allow to guarantee correct fluid speed; see diagram in paragraph 9.9
2. The first section of the hose connected to the pump must be flexible in order to isolate pump vibrations from the rest of the system.
3. Use high pressure hoses and fittings that guarantee wide safety margins in any working condition.
4. Install a safety valve on the delivery line.
5. Use pressure switches suitable for the pulsating loads typical of plunger pumps.
6. In the design phase, take into proper account the pressure drop along the line, since this causes a reduction in usage pressure with respect to the value measured at the pump.
7. If the pump pulsations are harmful for particular applications, install an appropriately sized pulsation dampener on the outlet line.

### 9.9 Internal Diameter of the Hose Line

To determine the internal diameter of the hose, please refer to the following diagram.

#### Suction Hose

With a flow rate of ~105 GPM (400 l/mn) and water speed of 1 m/sec. the diagram line that connects the two scales intersects the central scale, indicating the diameters, at a value of ~ 3.5 inch (90 mm).

#### Delivery Hose

With a flow rate of ~105 GPM (400 l/mn) and water speed of 5.5 m/sec. The diagram line that connects the two scales intersects the central scale, indicating the diameters at a value of ~ 1.6 inch (40 mm).

#### Optimal speed to be obtained with the booster pump:

- Suction: ≤ 1 m/sec.
- Delivery: ≤ 5.5 m/sec.

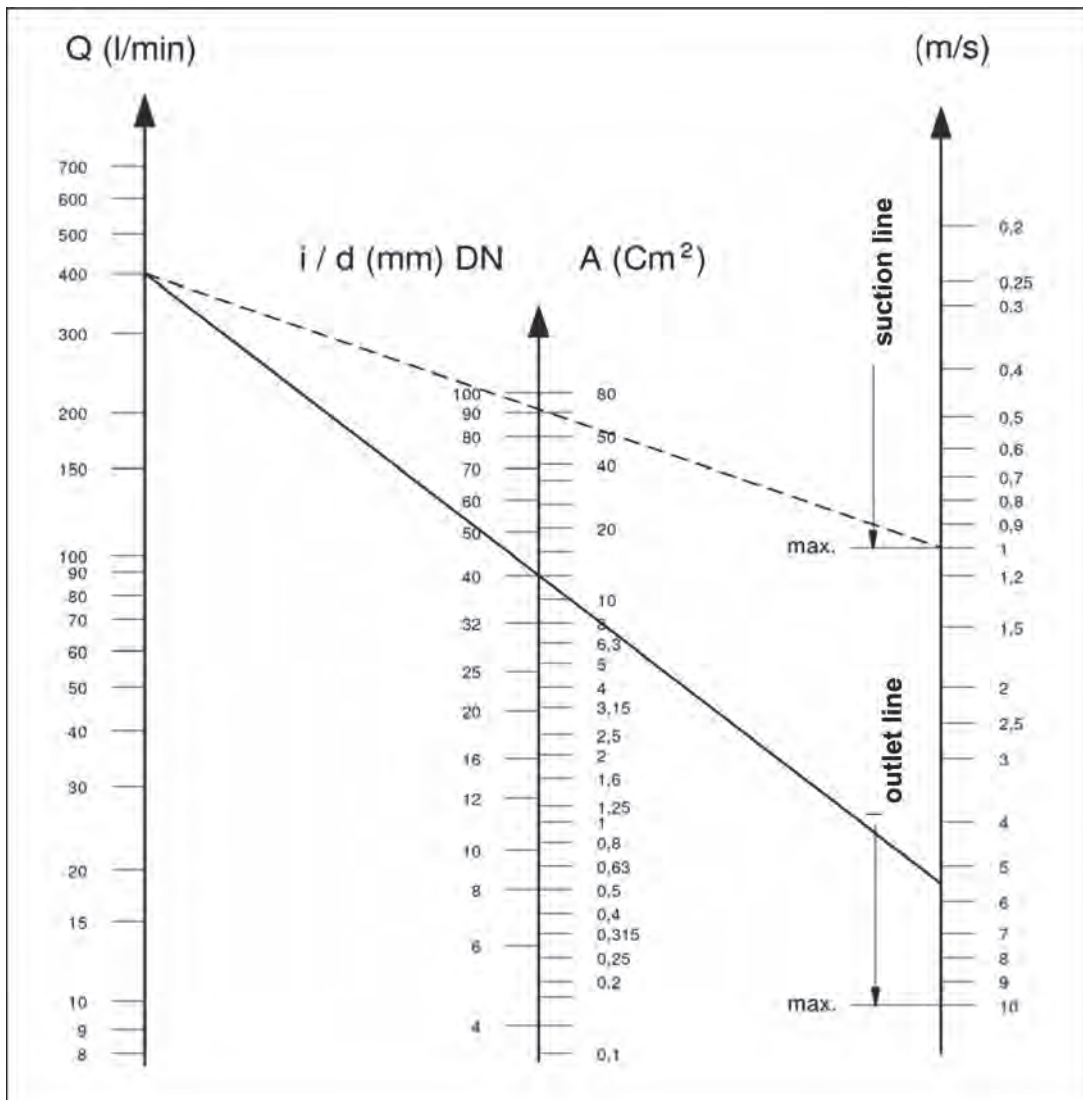

The diagram does not take into account the hose and valve resistance, the pressure drop due to the pipe length, the viscosity and the temperature of the pumped fluid. If necessary, contact our Customer Service Department.

## 9.10 V-belt Transmission

As indicated in paragraph 9.1, only in exceptional cases may the pump be driven by a v-belt system. For correct lay-out sizing, please contact our Customer Service Department.

## 10. START-UP AND OPERATION

### 10.1 Preliminary Inspections

Before Start-up Be sure that:



**The suction line is connected and up to pressure (see Chapter 9) the pump must never run dry.**

1. The suction line must be perfectly airtight.
2. All the On-Off valves between the pump and the feeding source are completely open. The delivery line must discharge freely in order to allow the air in the pump to be expelled easily, thus facilitating pump priming.
3. All suction/delivery connections and fittings must be correctly tightened.
4. Coupling tolerances on the pump/transmission axis (half-joint misalignment, Cardan inclination, belt tightening, etc.) must remain within the limits indicated by the transmission Manufacturer.
5. The pump's oil level must be verified using the correct dipsticks (position 1, fig 8).

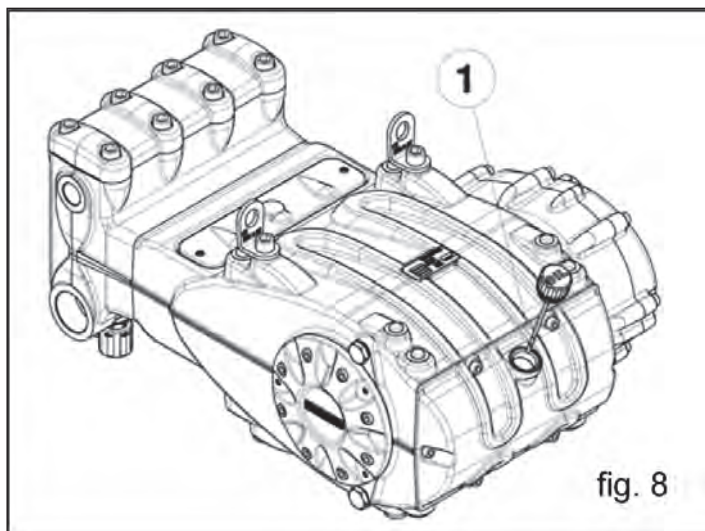

**In case the pump has not run for a long period of time, recover the correct operation of the suction valves by opening the three valve-lifting devices (see position 2, fig. 9). Be sure to reclose the valves before the pump start-up. See fig. 10 for “work” and “rest” positions.**

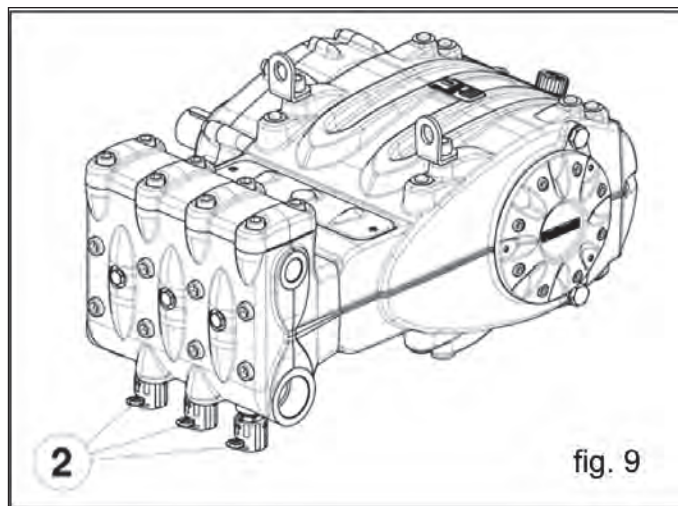
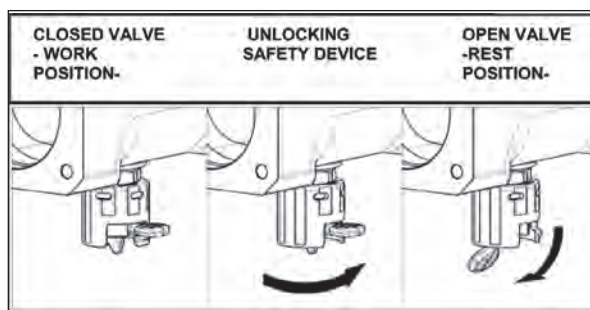

fig. 10



## 10.2 Start-up

1. When starting the pump for the first time, check for the correct direction of rotation.
2. The pump must be started off-load.
3. Verify correct feeding pressure.
4. During operation, check that the rotating speed does not exceed the rated value.
5. Before putting the pump under pressure let it run for at least 3 minutes.
6. Before stopping the pump, release the pressure by acting on the adjustment valve or on any discharging device.



**Whenever priming problems arise due to insufficient feeding, intervene by removing the three front plugs on the head (see position 3, fig. 11 and 11a).**

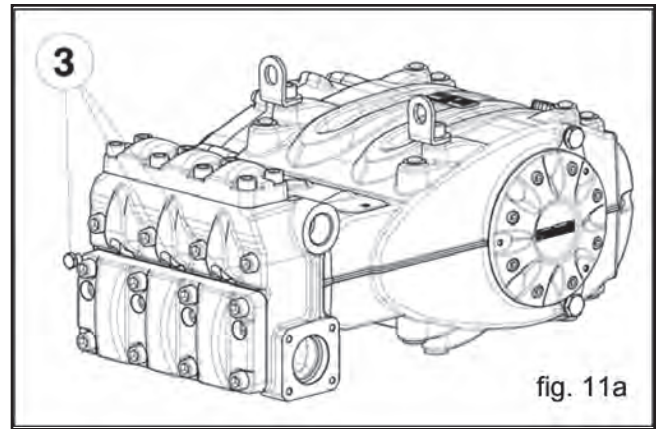
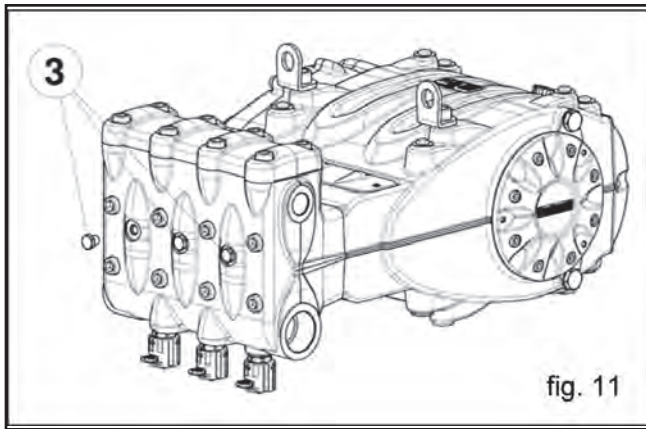

## 11. PREVENTIVE MAINTENANCE

To guarantee pump reliability and efficiency, comply with the maintenance intervals as indicated in the table below.

PREVENTIVE MAINTENANCE	
EVERY 500 HOURS	EVERY 1000 HOURS
Check oil level	Change oil
	Check / Replace:* <ul style="list-style-type: none"> <li>• Valves</li> <li>• Valve seats</li> <li>• Valve springs</li> <li>• Valve guides</li> </ul>
	Check / Replace: <ul style="list-style-type: none"> <li>• H.P packings</li> <li>• L.P. packings</li> </ul>

\* For replacement follow instructions contained in the repair manual.



## 12. PUMP STORAGE

### 12.1 Filling the Pump With An Anti-Corrosion Emulsion or Anit-freeze By Using An External Diaphragm Pump As In The Layout Shown in Paragraph 9.7.

- a) Close the filter draining, if open.
- b) Be sure that the connecting hose is clean, spread with grease and connect it to the high pressure outlet port.
- c) Fit a suction hose to the membrane pump. Open the pump suction connection and fit hose between it and the membrane pump.
- d) Fill the container with the solution/emulsion.
- e) Put the free extremities of the suction line and the high pressure outlet hose inside the container.
- f) Start up the diphragm pump.
- g) Pump the emulsion until it comes out of the high pressure hose.
- h) Continue pumping for at least another minute; if needed, the emulsion can be reinforced by adding, for example, Shell Donax
- i) Stop the pump, remove the hose from the suction connection and close it with a plug.
- j) Remove the hose from the high pressure outlet port. Clean, grease and plug both connections and the hoses.

### 12.2 Hoses

- a) Before greasing and protecting the hoses according to the previously described procedure, dry the connections using compressed air.
- b) Cover with polyethylene.
- c) Do not wrap them too tightly; be sure there is no bending.

## 13. PRECAUTIONS AGAINST FREEZING



In areas and periods of the year where there is risk of freezing, follow the instructions indicated in Chapter 12 (see paragraph 12.1).



**In the presence of ice, in no case must the pump be started until the entire circuit has been completely thawed out; not complying with this indication may cause serious damage to the pump.**

## 14. WARRANTY TERMS

The pump is guaranteed for a period of 5 years from the delivery date, with the exception of parts subject to wear. In any case, please refer to the contract terms for other warranty conditions. The warranty is void if:

- a) The pump has been used for purposes that differ from that agreed.
- b) The pump has been fit with an electric or diesel engine with performance greater than that indicated in the table.
- c) The required safety devices were un-adjusted or disconnected.
- d) The pump was used with accessories or spare parts not supplied by General Pump.
- e) Damage was caused by:
  - 1) improper use
  - 2) the non-observance of maintenance instructions
  - 3) use not compliant with operating instructions
  - 4) insufficient flow rate
  - 5) faulty installation
  - 6) incorrect positioning or sizing of the hoses
  - 7) non-authorized design changes
  - 8) cavitation



**15. TROUBLESHOOTING****The pump does not produce any noise at start-up:**

- The pump is not primed and is running dry
- There is no water in the inlet line
- The valves are blocked
- The delivery line is closed and does not allow the air in the pump to be discharged

**The pump pulses irregularly (knocking):**

- Air suction
- Insufficient feeding
- Bends, elbows, fittings along the suction line obstruct the fluid's passage
- The inlet filter is dirty or too small
- The booster pump, where provided, supplies insufficient pressure or flow rate
- The pump is not primed due to insufficient head or the delivery line is closed during priming
- The pump is not primed due to valve seizing
- Worn valves
- Worn pressure packings
- Incorrect operation of the pressure adjustment valve
- Transmission problems

**The pump does not deliver the rated flow / is noisy:**

- Insufficient feeding (see the causes listed above)
- RPM are less than the rated flow
- Excessive amount of water by-passed by the pressure adjustment valve



- Worn valves
- Leakage from the pressure packings
- Cavitation due to:
  - 1) Wrong sizing of the suction hose/undersized diameters
  - 2) Insufficient flow rate
  - 3) High water temperature

**Insufficient pump pressure:**

- The nozzle (or has become) too large
- Insufficient RPM
- Leakage from the pressure packings
- Incorrect operation of the pressure adjustment valve
- Worn valves

**Overheated pump:**

- The pump is overloaded (pressure or RPM exceed the rated values)
- Oil level is too low, or the oil is not of a suitable type, indicated in Chapter 7 (see paragraph 7.4)
- Incorrect alignment of the joint or pulleys
- Excessive inclination of the pump during operation

**Pump vibrations or knocking:**

- Air suction
- Incorrect operation of the pressure adjustment valve
- Valve malfunction
- Irregular drive transmission motion

**16. EXPLODED VIEW AND PARTS LIST**

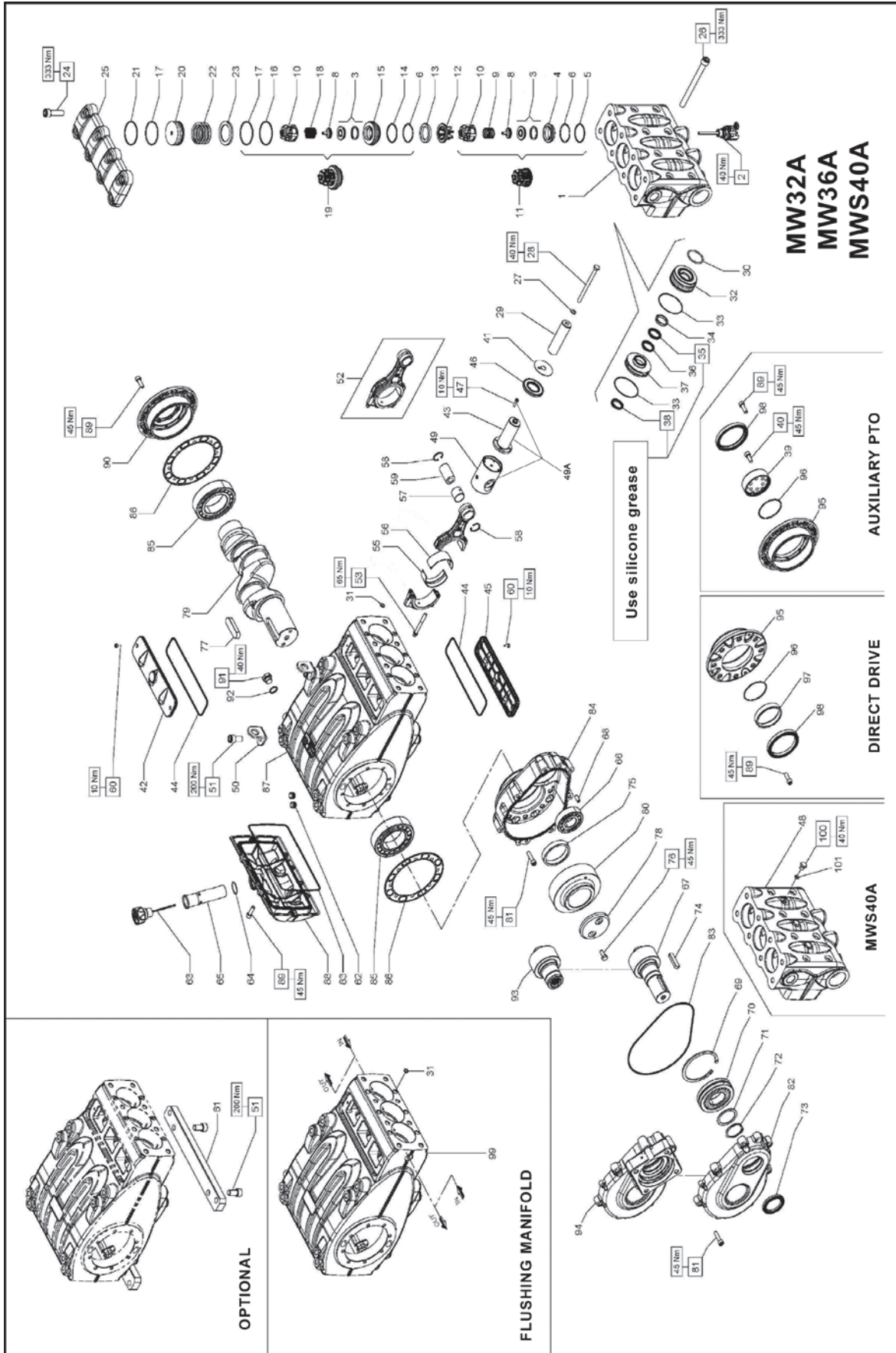

Item	Part #	Description	QTY.
1	F73120215	MANIFOLD-NPT	1
2	F10744401	DRAIN VALVE	3
3	F36208801	BALL VALVE ASSEMBLY	6
4	F36206766	INLET VALVE HOUSING	3
5	F90526000	ANTIEXTRUSION RING Ø51.5x56x1.5	3
6	F90389000	OR, Ø50.47X2.62	6
8	F36209051	INTERNAL VALVE GUIDE	6
9	F94760000	SPRING Ø 28.3X30.7	3
10	F36206105	INLET/OUTLET VALVE GUIDE	6
11	F36715101	INLET VALVE UNIT	3
12	F74210651	HP VALVE GUIDE SPACER	3
13	F73212270	OR, Ø 10.82X1.78	3
14	F90526500	ANTIEXTRUSION RING Ø 51.7X56.2X1.5	3
15	F36206966	OUTLET VALVE HOUSING	3
16	F90527600	ANTIEXTRUSION RING Ø 67.7X72.2X1.5	3
17	F90391100	OR, Ø 66.35X2.62	6
18	F94760500	SPRING Ø 28.5X32	3
19	F36715301	OUTLET VALVE UNIT	3
20	F74211070	HP OUTLET VALVE PLUG	3
21	F90528000	ANTIEXTRUSION RING Ø 67.7X72.2X1.5	3
22	F94775000	SPRING Ø 58X45.4	3
23	F74210866	OUTLET VALVE HOUSING RING	3
24	F99514700	SCREW, M16x180	8
25	F73210715	VALVE COVER	1
26	F99522200	SCREW, M16x180	8
27	F96710500	WASHER Ø 10X18X0.9, SS, PTFE	3
28	F99383000	SCREW, M10X140	3
29	F73040009	PLUNGER Ø 32	3
	F73040109	PLUNGER Ø 36	3
	F73040209	PLUNGER Ø 49	3
30	F90408500	O-RING, 49.21X3.53	3
31	901111	O-RING, 10.78X2.62	6
32	F73211656	PLUNGER LINER Ø 32	3
	F73211756	PLUNGER LINER Ø 36	3
	F73211856	PLUNGER LINER Ø 40	3
33	F90371000	OR, Ø 81X2	6
	F73100092	PLUNGER HEAD RING Ø 32	3
34	F78100192	PLUNGER HEAD RING Ø 36	3
	F74100092	PLUNGER HEAD RING Ø 40	3
35	F90278800	ALT. SEAL RING, Ø 32, HP	3
	90282060	ALT. SEAL RING, Ø 36, HP	3
	F90283200	ALT. SEAL RING, Ø 40, HP	3
36	F90278400	RESTOP RING Ø 32	3
	90281800	RESTOP RING Ø 36	3
	F90283800	RESTOP RING Ø 40	3
37	F73211068	SEAL SUPPORT, Ø 32	3
	F73211168	SEAL SUPPORT, Ø 36	3
	F73211268	SEAL SUPPORT, Ø 40	3
	F90278000	ALT. SEAL RING, LP, Ø 32	3
38	F90279800	ALT. SEAL RING, LP, Ø 36	3
	F90282800	ALT. SEAL RING, LP, Ø 40	3
41	F96735500	WASHER, Ø16x65X1	3
42	F73150022	CLOSED INSPECTION COVER	1
43	F73050336	PISTON GUIDE ROD	3
44	F90414800	OR, Ø 202.8X3.53	2
45	F73150122	OPEN INSPECTION COVER	1
46	F90168500	RAD. RING, Ø 40X72X7/8.5	3
47	99188400	SCREW, M6X20	3
48	F73120815	MANIFOLD FOR PISTON	1
49	F73050443	PISTON GUIDE	3
	F73050543	PISTON GUIDE, +0.10	3
49A	F73606201	PISTON GUIDE ASSEMBLY	3
50	F73210674	LIFTING BRACKET	2
51	F99513000	SCREW, M16x30, UNI 5931	4
52	F73030101	CONNECTING ROD ASSY.	3
53	F99378800	CONNECTING ROD SCREW	6
	F90928300	CONROD HEAD SEMI-BUSHING, LOWER	3
55	F90928400	CONROD HEAD SEMI-BUSHING, LOWER, +0.25	3
	F90928500	CONROD HEAD SEMI-BUSHING, LOWER, +0.50	3

Item	Part #	Description	QTY.
	F90928000	CONROD HEAD SEMI-BUSHING, UPPER	3
56	F90928100	CONROD HEAD SEMI-BUSHING, UPPER, +0.25	3
	F90928200	CONROD HEAD SEMI-BUSHING, UPPER, +0.50	3
57	F90915800	CONROD FOOT BUSHING	3
58	F90069000	STOP RING, Ø 32, UNI 7437	6
59	F97744000	SPINDLE	3
60	99183700	SCREW, M6x14, UNI 5931	4
61	F73200064	FOOT	2
62	98206000	HOLE PLUG. Ø 15, TTN18	6
63	F98233500	OIL FILLING PLUG, G1" WITH ROD	1
64	90361600	OR, Ø 34.65X1.78	1
65	F73210295	TUBE FOR OIL FILLING PLUG, G1"	1
66	F91854000	CYL. ROLLER BEARING	1
	F10076735	PINION, Z24 R1.875, HELICOL	1
	F10076835	PINION, Z21 R2.238, HELICOL	1
	F10076935	PINION, Z18 R2.722, HELICOL	1
	F10082255	PINION, Z19 R3.211, HELICOL	1
68	F97623000	TMP. CYL. PIN. Ø 10X24, UNI 6364	2
69	F90101000	STOP RING, Ø 120, UNI 7437	1
70	F91859900	ADJUST ROLLER BEARING	11
71	F73210455	BEARING SUPPORT RING	1
72	F90081000	STOP RING, Ø 55, UNI 7435	1
73	F90172400	RAD. RING, Ø 55X75X8, VITON	1
74	F91500500	TAB, 14X9X60, UNI 6604	1
75	F73210589	RING GEAR SUPPORT RING	1
76	99366700	SCREW, M10X25, UNI 5739	2
77	F91511000	TAB, 22X14X80, UNI 6604	1
78	F74213255	RING GEAR STOP	1
79	F73020035	CRANKSHAFT C. 70	1
	F10077035	RING GEAR, Z45 R1.875, HELICAL	1
	F10077135	RING GEAR, Z47 R2.238, HELICAL	1
	F10077235	RING GEAR, Z49 R2.722, HELICAL	1
	F10082355	RING GEAR, Z61 R3.211, HELICAL	1
81	F99371000	SCREW, M10X40, UNI 5931	15
82	F73210113	REDUCTION GEAR COVER	1
83	F90415000	OR, Ø 253.6.X3.53	2
84	F73210013	REDUCTION GEAR BOX	1
85	F91881000	CYL ROLLER BEARING	2
86	F73210384	SIDE SEAL	2
87	F73010013	PUMP CASING	1
88	F73160022	CASING COVER	1
89	F99368600	SCREW, M10X30, UNI 5931	14
90	F73150222	BEARING COVER	1
91	F98218700	PLUG, G1/2"X13, SS	2
92	91751400	WASHER, Ø 21.5x27x1.5	2
100	98204600	PLUG, 1/4"X13	3
101	90358400	O-RING, Ø10.82X1.78	3
<b>FLUSHING MANIFOLD</b>			
99	F73010113	PUMP CASING, FLUSHING	1
<b>WITH HYDRAULIC MOTOR</b>			
	F10079455	PINION, Z18 R. 2.722	1
93	F10077355	PINION, Z24 R. 1.875	1
	F10077455	PINION, Z21 R. 2.238	1
94	F73215513	HYDRAULIC GEAR COVER	1
<b>DIRECT DRIVE</b>			
89	F99368600	SCREW, M10X30, UNI 5931	8
95	F73150322	BEARING COVER, OPEN	1
96	F90391450	O-RING, Ø75.87X2.62	1
97	F73215654	RING	1
98	F90195000	RING, RAD., Ø90X110X12	1
<b>AUXILIARY PTO</b>			
39	F73215754	DRAIN	1
40	99367100	SCREW, M8X25	6
89	F99368600	SCREW, M10X30, UNI 5931	8
95	F73150322	BEARING COVER, OPEN	1
96	F90391450	O-RING, Ø75.87X2.62	1
98	F90195000	RING, RAD., Ø90X110X12	1
100	F73215754	PTO OUTLET	1
101	99367100	SCREW, M10X25	6

### REPAIR KITS

KIT NUMBER	F2136 (MW32A) Plunger Packing Kit	F2137 (MWS36A) Plunger Packing Kit	F2138 (MWS40A) Plunger Packing Kit	F2055 Valve Kit	F2144 (MW32A) Complete Seals Kit	F2145 (MWS36A) Complete Seals Kit	F2146 (MWS40A) Complete Seals Kit	F2150 Conn.Rod Kit	F2151 Conn. Rod Kit +0.25	F2153 Conn. Rod Kit +0.50
Positions Included	30, 31, 33, 35, 36, 38,	30, 31, 33, 35, 36, 38,	30, 31, 33, 35, 36, 38,	11, 12, 19, 21	5, 6, 14, 16, 17, 21, 30, 31, 33, 35, 36, 38, 44, 46, 64, 73, 83, 86, 101	5, 6, 14, 16, 17, 21, 30, 31, 33, 35, 36, 38, 44, 46, 64, 73, 83, 86, 101	5, 6, 14, 16, 17, 21, 30, 31, 33, 35, 36, 38, 44, 46, 64, 73, 83, 86, 101	55, 56	55, 56	55, 56

**16. EXPLODED VIEW AND PARTS LIST**

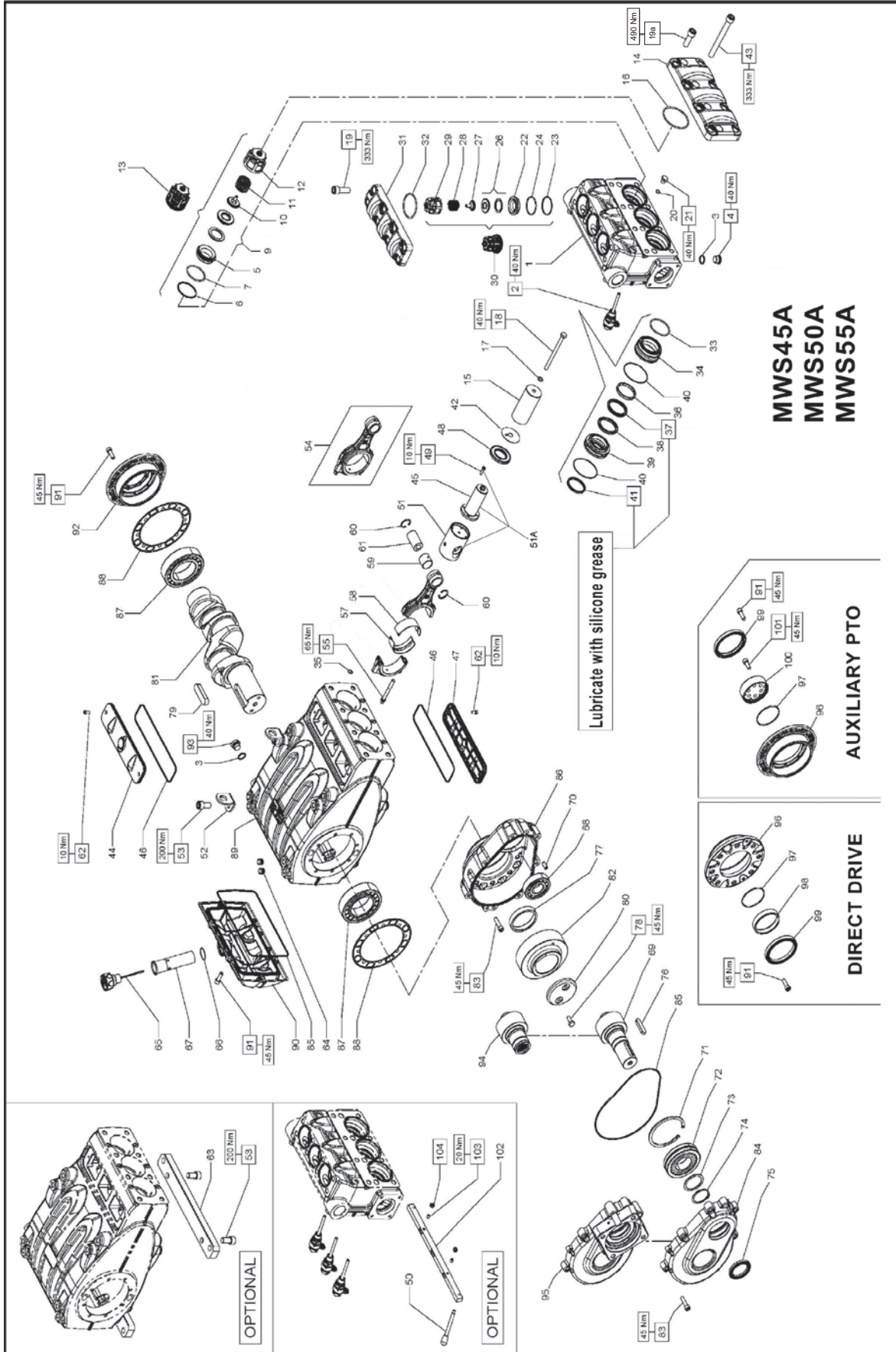



Item	Part #	Description	QTY.
1	F73121601	MANIFOLD, NPT, HR	1
2	F10744501	VALVE OPENING DEVICE	3
3	F96751400	WASHER, Ø 21.5X27X1.5	5
4	F98218500	STEEL PLUG, 1/2"	3
5	F36206666	INLET VALVE HOUSING	3
6	F90527000	ANTI-EXTRUSION RING, Ø 61.2X67X2	3
7	F90410500	OR, Ø 59.62X3.53	3
9	F36208701	BALL VALVE ASSY.	3
10	F36208951	INTERNAL VALVE GUIDE	3
11	F94769800	SPRING, Ø41.5X37.9	3
12	F36206005	INLET VALVE GUIDE	3
13	F36715001	INLET VALVE UNIT	3
14	F73225615	INLET VALVE COVER	1
	F73040309	PLUNGER, Ø 45X117	3
15	F73040409	PLUNGER Ø 50X117	3
	F73040509	PLUNGER Ø 55X117	3
16	F90414200	OR, Ø 85.32X3.53	3
17	F96710500	WASHER, Ø 10X18X0.9,SS, PTFE	3
18	F99383000	SCREW, M10X140	3
19	F99514200	SCREW, M16X45	8
19a	F99525000	SCREW, M18	8
20	F90358400	OR, Ø 10.82X1.78	3
21	F98204600	PLUG, G 1/4"X13, SS	3
22	F36206766	OUTLET VALVE HOUSING	3
23	F90526000	ANTI-EXTRUSION RING, Ø 51.5X56X1.5	3
24	F90389000	OR, Ø 50.47X2.62	3
26	F36208801	BALL VALVE ASSY.	3
27	F36209051	INTERNAL VALVE GUIDE	3
28	F94760500	SPRING, Ø 28.5X32	3
29	F36206105	OUTLET VALVE GUIDE	3
30	F36207701	OUTLET VALVE UNIT	3
31	F73210915	OUTLET VALVE COVER	1
32	F90412000	OR, Ø 68.26X3.53	3
33	F90411500	OR, Ø 63.5X3.53	3
	F73211956	LINER, Ø 45	3
34	F73212056	LINER, Ø 50	3
	F73212156	LINER, Ø 55	3
35	F90382500	OR, Ø 10.78X2.62	6
	F74100192	PISTON HEAD RING, Ø 45	3
36	F74100292	PISTON HEAD RING, Ø 50	3
	F74100392	PISTON HEAD RING, Ø 55	3
	F90285000	ALT. SEAL RING, HP, Ø 45	3
37	F90286300	ALT. SEAL RING, HP, Ø50	3
	F90287300	ALT. SEAL RING, HP, Ø 55	3
	F90284800	RESTOP RING, Ø 45	3
38	F90286500	RESTOP RING, Ø 50	3
	F90287500	RESTOP RING, Ø 55	3
	F73211368	SEAL SUPPORT, Ø 45	3
39	F73211468	SEAL SUPPORT, Ø 50	3
	F73211568	SEAL SUPPORT, Ø 55	3
40	F90371000	OR, Ø 81X2	6
	F90284600	ALT. SEAL RING, LP, Ø 45	3
41	F90286000	ALT. SEAL RING, LP, Ø 50	3
	F90287000	ALT. SEAL RING, LP, Ø 55	3
42	F96735500	WASHER, Ø 16X65X1	3
43	F99521200	SCREW, M16X150	8
44	F73150022	CLOSED INSPECTION COVER	1
45	F73050336	PLUNGER GUIDE ROD	3
46	F90414800	OR, Ø202.8X3.53	2
47	F73150122	OPEN INSPECTION COVER	1
48	F90168500	RAD. RING, Ø40X72X7/8.5	3
49	F99188400	SCREW, M6XX20	3
50	F94540000	SCREW, M8X107	1
51	F73050443	PLUNGER GUIDE	3
	F73050543	PLUNGER GUIDE, +0.10	3
51A	F73606201	PISTON GUIDED ASSEMBLY	3
52	F73210674	LIFTING BRACKET	2
53	F99513000	SCREW, M16x30, UNI 5931	4
54	F73030101	CONNECTING ROD ASSY.	3
55	F99378800	CONNECTING ROD SCREW, M10X1.5X80	6

Item	Part #	Description	QTY.
	F90928000	CONROD HEAD SEMI-BUSHING, LOWER	3
57	F90928400	CONROD HEAD SEMI-BUSHING, LOWER, +0.25	3
	F90928500	CONROD HEAD SEMI-BUSHING, LOWER, +0.50	3
	F90928300	CONROD HEAD SEMI-BUSHING, UPPER	3
58	F90928100	CONROD HEAD SEMI-BUSHING, UPPER, +0.25	3
	F90928200	CONROD HEAD SEMI-BUSHING, UPPER, +0.50	3
59	F90915800	CONROD HEAD FOOT BUSHING	3
60	F90069000	STOP RING, Ø 32 UNI 7437	6
61	F94744000	SPINDLE	3
62	F99183700	SCREW, M6X14, UNI 5931	4
63	F73200064	FOOT	2
64	F98206000	HOLE PLUG, Ø 15	6
65	F98233500	OIL FILLING PLUG, G1", WITH ROD	1
66	F90361600	OR, 34.65X1.78	1
67	F73210295	TUBE FOR OIL FILLING PLUG, G1 "	1
68	F91854000	CY. ROLLER BEARING	1
	F10076735	PINION, Z24 R1.875, HELICOL	1
	F10076835	PINION, Z21 R2.238, HELICOL	1
	F10076935	PINION, Z18 R2.722, HELICOL	1
	F10082255	PINION, Z19 R3.211, HELICOL	1
70	F97623000	TMP. CYL. PIN, Ø 10X24	2
71	F90101000	STOP RING, Ø 120	1
72	F91859900	ADJUST. ROLLER BEARING	1
73	F73210455	BEARING SUPPORT RING	1
74	F90081000	STOP RING, Ø 55	1
75	F90172400	RAD. RING, Ø 55X75X8, VITON	1
76	F91500500	TAB, 14X9X60, UNI 6604	1
77	F73210589	RING GEAR SUPPORT RING	1
78	F99366700	SCREW, M10X25, UNI 5739	2
79	F91511000	TAB, 22X14X80 UNI 6604	1
80	F74213255	RING GEAR STOP	1
81	F73020035	CRANKSHAFT C. 70	1
	F10077035	RING GEAR, Z45 R1.875, HELICAL	1
	F10077135	RING GEAR, Z47 R2.238, HELICAL	1
	F10077235	RING GEAR, Z49 R2.722, HELICAL	1
	F10082355	RING GEAR, Z61 R3.211, HELICAL	1
83	F99371000	SCREW, M10X40, UNI 5931	15
84	F73210113	REDUCTION GEAR COVER	1
85	F90415000	OR, Ø 253.6X3.53	2
86	F73210013	REDUCTION GEAR BOX	1
87	F91881000	CY. ROLLER BEARING	2
88	F73210384	SIDE SEAL	2
89	F73010013	PUMP CASING	1
90	F73160022	CASING COVER	1
91	F99368600	SCREW, M10X30, UNI 5931	14
92	F73150222	BEARING COVER	1
93	F98218700	PLUG, G1/2"X13, NICKEL	2
102	F73215864	VALVE UNION BRACKET	1
103	F99301800	SCREW, M8X10	2
104	F92221800	NUT, M8X1.125X13	2
<b>WITH HYDRAULIC MOTOR</b>			
	F10079455	PINION, Z18 R.2.722	1
94	F10077355	PINION, Z24 R.1.875	1
	F10077455	PINION, Z21 R.2.238	1
95	F73215513	HYDRAULIC GEAR COVER	1
<b>DIRECT DRIVE</b>			
91	F99368600	SCREW, M10X30, UNI 5931	8
96	F73150322	BEARING COVER, OPEN	1
97	F90391450	O-RING, Ø 75.87X2.62	1
98	F73215654	RING	1
99	F90195000	RING, RAD. Ø 90X110X12	1
<b>AUXILIARY PTO</b>			
91	F99368600	SCREW, M10X30, UNI 5931	8
96	F73150322	BEARING COVER, OPEN	1
97	F90391450	O-RING, Ø 75.87X2.62	1
99	F90195000	RING, RAD. Ø 90X110X12	1
100	F73215754	PTO OUTLET	1
101	F99367100	SCREW, M10x25	6

**REPAIR KITS**

KIT No.	F2139 (MW45A) Plunger Packing Kit	F2140 (MW50A) Plunger Packing Kit	F2141 (MW55A) Plunger Packing Kit	F2142 Inlet Valve Kit	F2062 Outlet Valve Kit	F2147 (MW45A) Complete Seals Kit	F2148 (MW50A) Complete Seals Kit	F2149 (MW55A) Complete Seals Kit	F2150 Con. Rod Kit	F2151 Con. Rod Kit	F2153 Con. Rod Kit	F2482 Manifold Conv. Kit
Positions Included	33, 35, 37, 38, 40, 41	33, 35, 37, 38, 40, 41,	33, 35, 37, 38, 40, 41,	13	30	6, 7, 16, 20, 23, 24, 32, 33, 35, 37, 38, 40, 41, 46, 48, 66, 75, 85, 88	6, 7, 16, 20, 23, 24, 32, 33, 35, 37, 38, 40, 41, 46, 48, 66, 75, 85, 88	6, 7, 16, 20, 23, 24, 32, 33, 35, 37, 38, 40, 41, 46, 48, 66, 75, 85, 88	57, 58	57, 58	57, 58	1, 14, 19a